

Aesthetic/High quality light/Affordable price/Genuine



Model 产品型号	Power 功率 [w]	Voltage 电压 AC [v]	Beam Angle 发光角度	Lumen 流明 [lm]	CCT 色温 [K]	CRI 显色指数	Dimensions 灯具尺寸 [mm]	Cut Size 开孔尺寸 [mm]	Net Weight 重量 [g]
ECD-5w	5W ± 10%	100 - 240	120°	>700	3000-6500	83	Ø115*20	Ø95	350
ECD-12w	12w ± 10%	100 - 240	120°	>1200	3000-6500	83	Ø160*20	Ø135	700
ECD-18w	18w ± 10%	100 - 240	120°	>1650	3000-6500	83	Ø181*20	Ø155	900
ECD-24w	24w ± 10%	100 - 240	120°	>1900	3000-6500	83	Ø230*20	Ø200	1300

\* WW(Warm white: 2700 - 3500K), CW(Cool white 4000 - 4500K), DL(Daylight: 6000 - 6500K) | **3 in 1 colour available too.**

\* Using Epistar 5730 LED chipset

\* Additional \$15.00 for Dimmable function available

## PHOTOMETRIC PARAMETER 实测光参数分布图

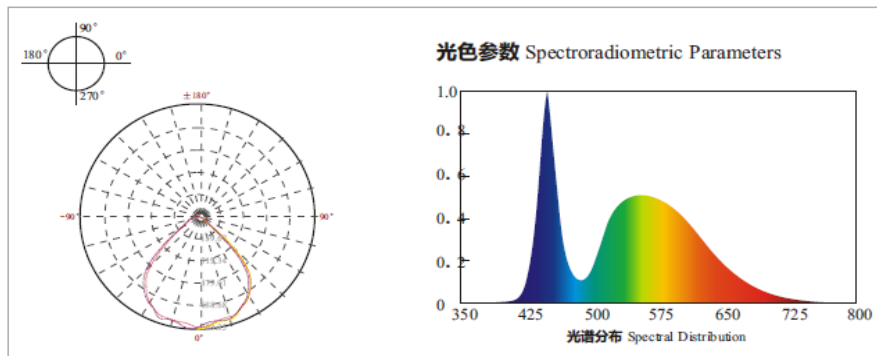

## SIZE 尺寸

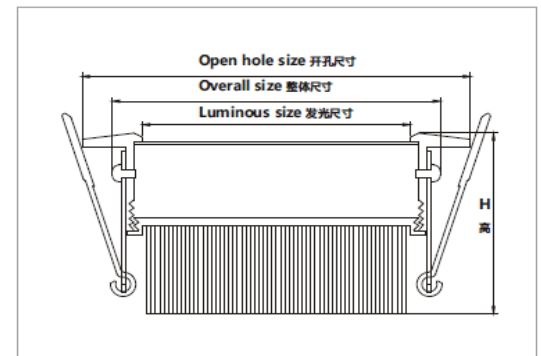

## Product Introduction 产品介绍

Elektra C – Downlight with glass trimming is a high quality LED lamp in an aesthetically crafted exterior. This downlight is widely adopted in commercial spaces and homes. A Elektra™ Square downlight of 6 inch 12w is suitable for replacing 24w CFLs and >80w incandescent lamps to achieve a cost savings of at least 55% in electricity usage. User can expect to break-even between 6 months to 1 year based on 6 hours to 14 hours usage. Our Elektra™ series uses high quality Epistar 5730 LED chipset and driver from Taiwan to maximize durability, thus enhancing returns on investment for users.

## Features 产品特点

- Professional Optical Design, no visible dark spots on lamp, smooth and comfortable light effect;
- Glass edge trimming gives an added touch of class to your environment;
- Easy installation of direct plug and play to 230v AC;
- Slim, modern profile for easy installation in false ceiling befitting new homes and commercial spaces;
- The useful life can be 20,000 hours; Lifespan is 10 times longer than CFL;
- Strong heat dissipation achieved with advanced heat sink design and good aluminium.

