

Aesthetic/High quality light/Affordable price/Genuine



Model. 产品型号	Power 功率 [w]	Voltage 电压 AC [v]	Beam Angle 发光角度	Lumen 流明 [lm]	CCT 色温 [K]	CRI 显色指数	Dimmable 调光类型	Dimensions 灯具尺寸 [mm]	Cut Size 开孔尺寸 [mm]	Net Weight 重量 [g]
ECD-5w	5W ± 10%	100 - 240	120°	>450	3000-6500	83	Yes	Ø85*20	Ø80	200
ECD-12w	12w ± 10%	100 - 240	120°	>750	3000-6500	83	Yes	Ø170*20	Ø155	550
ECD-15w	15w ± 10%	100 - 240	120°	>1100	3000-6500	83	Yes	Ø200*20	Ø186	700
ECD-18w	18w ± 10%	100 - 240	120°	>1550	3000-6500	83	Yes	Ø225*20	Ø206	900
ECD-24w	24w ± 10%	100 - 240	120°	>1840	3000-6500	83	Yes	Ø300*20	Ø285	1300

* WW(Warm white: 2700 - 3500K), CW(Cool white 4000 - 4500K), DL(Daylight: 6000 - 6500K)

* Using Epistar 5730 LED chipset

* Additional \$15.00 for Dimmable function available

PHOTOMETRIC PARAMETER 实测光参数分布图

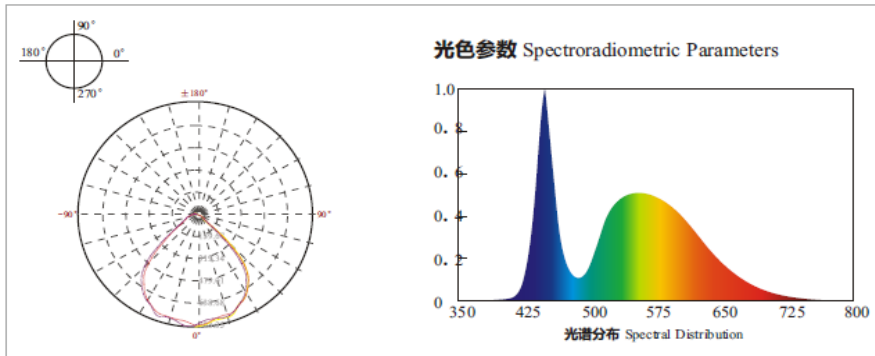

SIZE 尺寸

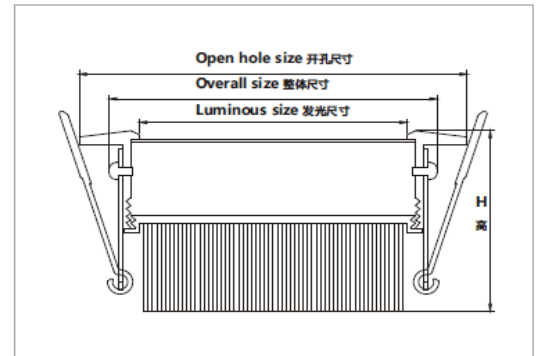

Product Introduction 产品介绍

Elektra™ C-Downlight is a high quality LED lamp in an aesthetically crafted exterior. With a comfortable lighting effect, the lamp is installed widely in both commercial and residential projects as the main lighting. A slim profile will ensure it fits well in to any false ceiling commonly available. It replaces conventional CFLs and incandescent lamps to achieve a greater cost savings of at least 50% in electricity used. We can assume a break-even period of 5 to 11 months under the operating hours of 6 to 14 hours per day. Using high quality Taiwan LED chipset and driver, the product seeks to maximize returns on investment for customers.

Features 产品特点

- Professional Optical Design, no visible dark spots on lamp, smooth and comfortable light effect
- High CRI, which is close to natural light
- Direct plug and play to 230v AC
- Extremely slim profile for easy installation in false ceiling
- The useful life can be 20,000 hours; Lifespan is 12 times longer than CFL
- Strong heat dissipation achieved with advanced heat sink design and good aluminium.

